

# SONIC ROTARY ARM - experience superior film economy



SONIC RTG

SONIC RTX

SEMI-AUTOMATIC ROTARY ARM

## TECHNICAL SPECIFICATIONS

RTX Arm Speed	Adjustable up to 14 RPM
RTG Arm Speed	Adjustable up to 16 RPM
Control Type	Full-Feature Semi-Automatic
Max. Load Height	84"
Max. Load Diameter	76"
Pre-Stretch Ratio	250% standard
Max. Load Size	54" x 54"
Electrical	115/1/60 15amp
Warranty	3/5 year limited

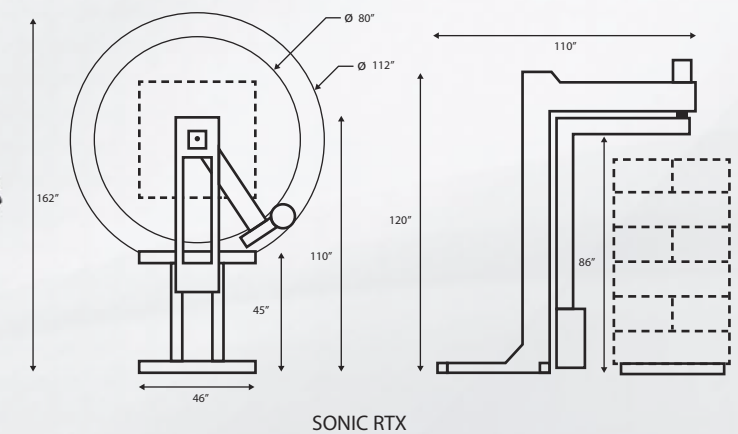
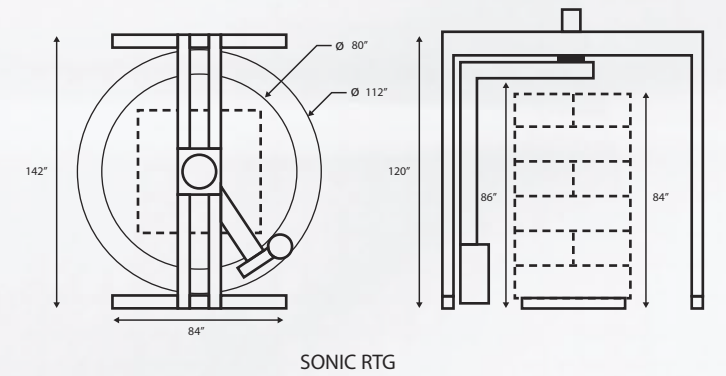

## POPULAR OPTIONS

- Wrap height extension for taller pallets
- Platform scale with digital weight indicator
- 30" film carriage
- Safety guarding around wrap zone
- Auto film cut
- Arm speed increase



The X-STRETCH pre-stretch film carriage provides superior film economy, film tension and user safety

- Uses 20" machine film
- Electronically adjustable film tension
- 250% film pre-stretch ratio, others available
- Maintenance free ball bearing carriage guide
- Automatic corner compensation
- Lifetime warranty on stretch rollers



The Sonic RTX and RTG features an all steel robust frame and the rotary arm ring gear support requires very little maintenance

- Structural steel frame
- Lag down pole stand (RTX)
- Gantry frame (RTG)
- Easy access to components
- 1/2 HP turntable drive motor
- Heavy duty arm tower chain drive
- Heavy duty ring bearing arm support



The versatile HMI touch screen allows for a quick setup to wrap various type pallet loads

- Photo-eye automatic height detection
- Separate top and bottom wrap count 1-10
- Rotary tower soft start/stop
- Dual adjustable film carriage speed
- Lockable wrap parameters access
- Safety photo-eye in front of rotary tower
- Automatic rotary tower home position